



PH-1 Hanger

PH-1 Hangers are typically used to isolate suspended fans, ductwork, fan-cool units, packaged air-conditioners, pipes, etc. They are also very effective for the support of suspended ceilings where acoustical isolation is required. The static deflection ranges from 2 to 5 mm. and features protection against complete loss of support in the event of mechanical or fire damage.

Load Capacity: 10 to 170 lbs.

Applications: hanger-elements for piping, acoustic ceilings, fans, air-conditioning units, sensitive equipment, etc.

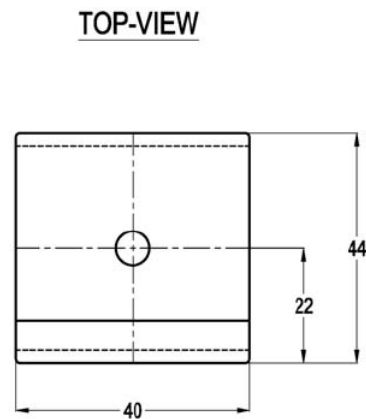
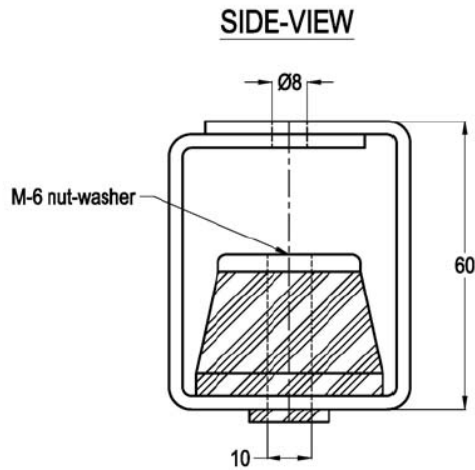
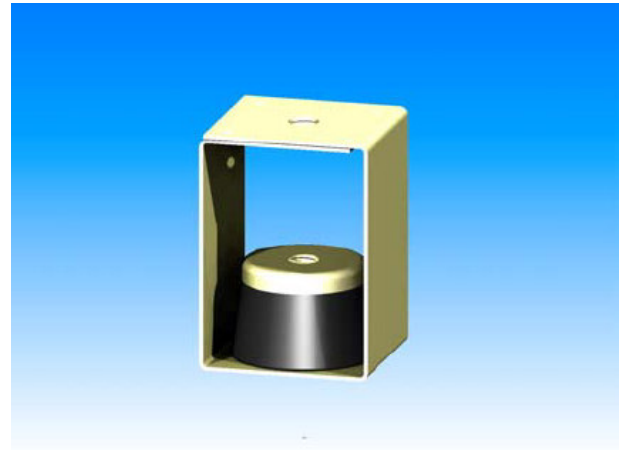

LOAD CHARACTERISTICS

